



CAR FILLING



DISPENSERS



PUMPS



METERS



NOZZLE METERS



NOZZLES

DELPHIN PRO_X

FEATURES

- FULLY AUTOMATIC
- 100% COMPATIBLE WITH ALL CARS AND VEHICLES**
- AUTOMATIC FLOW RATE REGULATION
- PRESET QUANTITY

The PIUSI Delphin Pro X is the ultimate solution for the AdBlue® car refilling: Pre-set function, automatic flow rate regulation, visual diagnostic alert.

PERFORMANCE

A

2-15 L/MIN

FLOW RATE

AC-DC

VOLTAGE

POWER

2M

HOSE LENGTH



DELPHIN PRO_X



PACKAGING

CODE	WEIGHT		PACKAGING			
	KG	LBS	MM	INCH	PCS/PALLET	PCS/BOX
FO0100400	43,5	96	770X1080X800	0,3X42,1X31,5	4	1
FO0100410	51	112,5	770X1080X800	0,3X42,1X31,5	4	1



FILTRATION



FLUID MONITORING



HOSE REELS



ACCESSORIES



MERCHANDISE



AIR



ANTIFREEZE



AdBlue®



BIODIESEL



DIESEL



FOOD



GASOLINE



GREASE



KEROSENE



OIL



WATER



WINDSCREEN

FUNCTIONING



AUTOMATIC FLOW RATE

The fastest automatic way to refill any car. Thanks to this option, Delphin Pro_X automatically adjust the flow rate according to the vehicle's tank.



PRESET

By pre-setting the needed quantity the operator can concentrate on something else while Delphin is refilling. Delphin PRO_X will stop automatically when the preset quantity will be reached.

IN THE BOX

- DELPHIN PRO_X UNIT
- AF2/SEC CONNECTOR
- INSTRUCTION MANUAL

DETAILS



UNIVERSAL ISO CONNECTOR



SEC VERSION AVAILABLE



AF2 CONNECTOR

MATERIALS

- PUMP:
- BODY: POLIPROPYLENE
- DIAPHRAGM: POLIPROPYLENE

DIMENSIONS

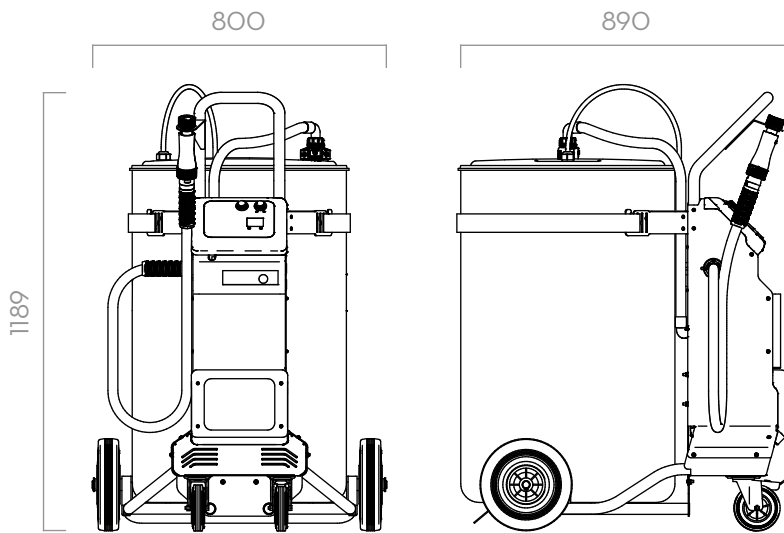

Dimensions expressed in millimeters

TECHNICAL DATA

CODE	DESCRIPTION	FLUIDS TYPE	FLOW-RATE		VOLTAGE			HOSE		ON/OFF
			L/MIN	GPM	AC V./HZ DC VOLT	POWER WATT	AMP. MAX.	LENGHT	Ø	SWITCH
FO0100400	DELPHIN PRO_X AC		2 - 15	0,5 - 4	230/50	260	2,2	2 M	3/4"	YES
FO0100410	DELPHIN PRO_X DC		2 - 15	0,5 - 4	230/50**	260*	2,2**	2 M	3/4"	YES

* BATTERY CHARGER

**ACCORDING TO ISO/FDIS 222241-4:2009

DELPHIN PRO_X